

TSK Ball Splines

TSK ball splines are ball circulating type spline bearing which are excellent cost performance with compact structure. They have semicircular ball grooves on the shaft and on the nut. Unlimited linear motions is possible by installing steel balls between grooves.

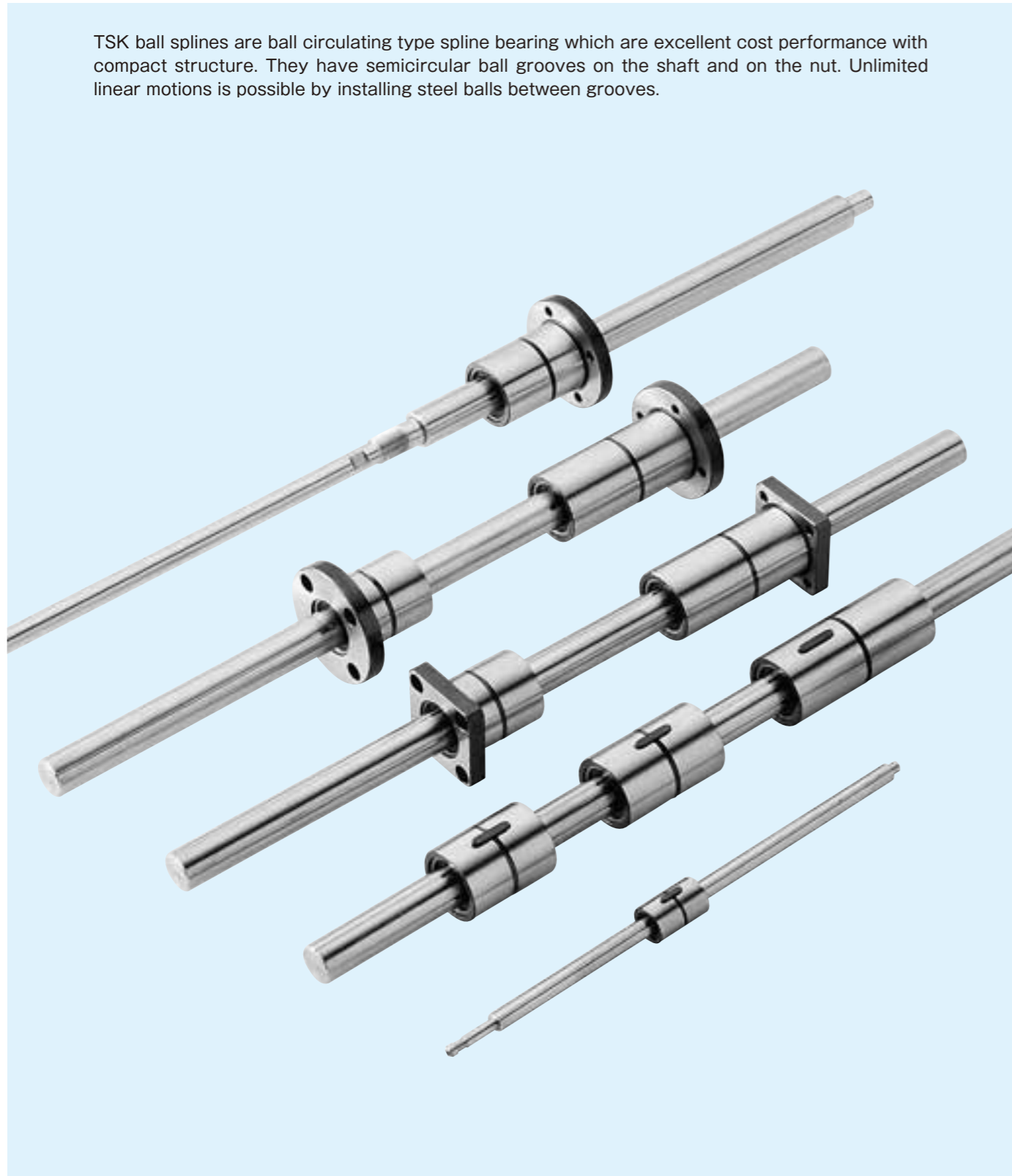

Features

- Semi-circular grooves, serving as rolling surface for the load carrying steel ball, furnish high loading capacity and long service life as ball splines.
- Circulating steel balls in the grooves enable torque transmission and linear motion of the shaft simultaneously.
- Ample nut types and standard stock of spline shafts are always available for various applications. Space saving type bearing consisting of two bearings within a nut is also available. This type has a high moment load capacity and is able to transmit big torque.
- Handling is simple because the steel ball is retained and they never fall off.
- For better prevention of corrosion, stainless steel and surface treatment are also available in addition to standard high carbon steel material.



Structure

TSK ball spline consists of a spline shaft and a spline nut moving on the shaft. This ball spline has unlimited stroke which is achieved by ball return structure provided in ball retainer and spline nut body.

Type of Nut

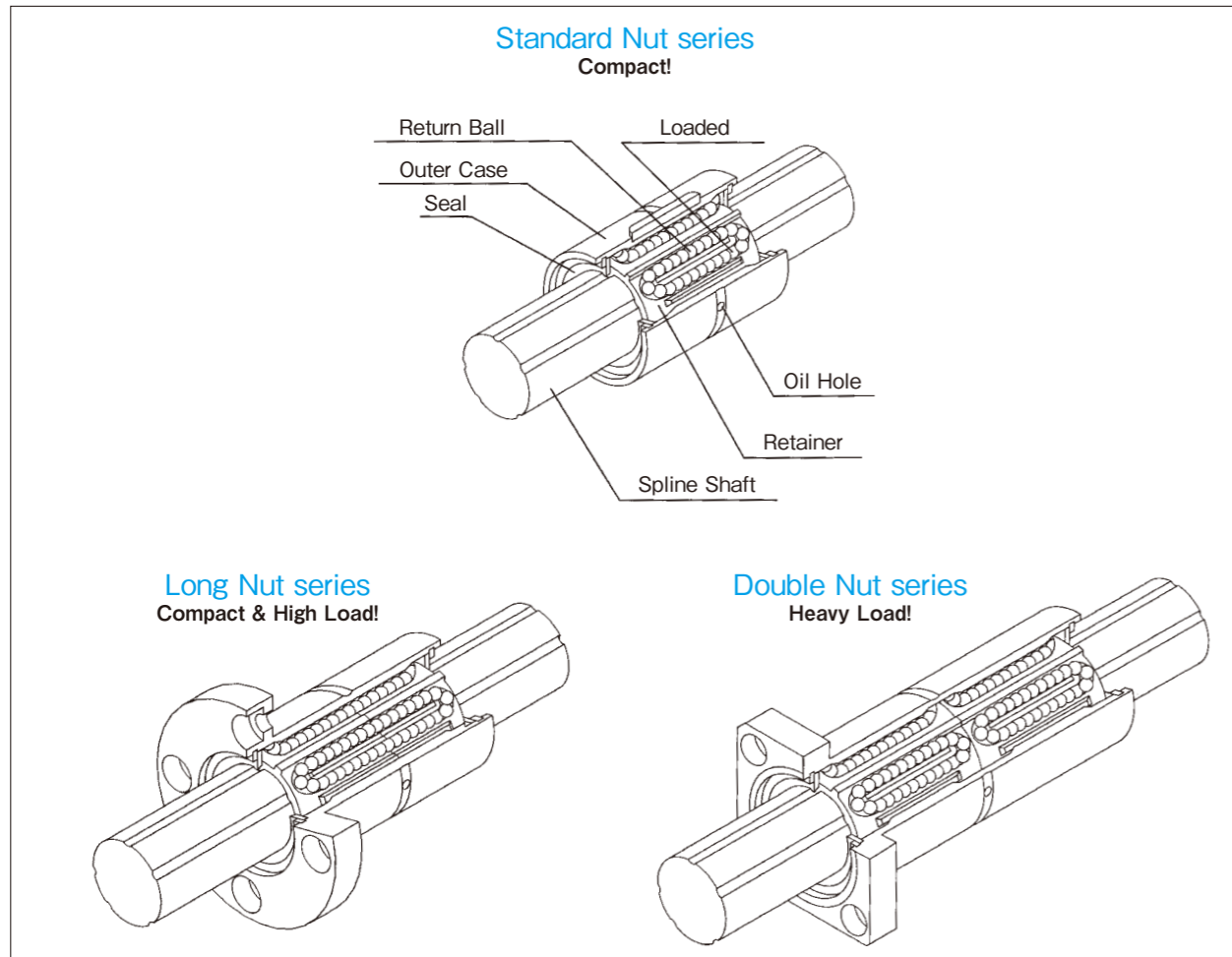

Raw Material and Heat treatment

● **Standard type**

Parts	Material	Heat Treatment	Hardness
Spline shaft	(JIS)SUJ2	Induction Hardening	More than HRC 58
Nut	(JIS)SCM415	Hardening	More than HRC 58
Ball Bearing	(JIS)SUJ2	Hardening	More than HRC 60
Retainer	Synthetic Resin	—	—

● **Stainless steel type**

Parts	Material	Heat Treatment	Hardness
Spline shaft	(JIS)SUS440C	Induction Hardening	More than HRC 55
Nut	(JIS)SUS440C	Hardening	More than HRC 55
Ball Bearing	(JIS)SUS440C	Hardening	More than HRC 55

• Please contact TSK for the information of raw materials for the parts other than above.

Specification Number

The spline shaft and the nut are supplied in set.

Please use the following code number for making order.

SBS25	UU	2	E	H	820	T	M
Model #.	Seal Blank : without seal UU : 2 seals	Number of nut per rail	Clearance E1 : Clearance Blank : Fine clearance E : Light preload E0 : Medium preload	Accuracy grade Blank : Normal H = High grade P = Precision grade	Shaft Length	Extra Machining L : no machining T : with machining	Shaft shape Blank : Solid M : Hollow

Accuracy Standard

The accuracy grade of TSK ball spline is classified as either normal (No mark), high (H) or precision (P). For accuracy grades not shown in table 1, contact TSK for available options.

Twist of grooves in effective length of spline part

Tolerance of twist of groove is expressed for arbitrary chosen 100 mm effective length of spline portion of spline shaft.

If relative movement between sleeve and spline shaft exceeds 100 mm, correct the tolerance in proportion to the stroke.

Table 1

Tolerance of twist (Max)		
Normal (No mark)	High (H)	Precision (P)
33 μ/100mm	13 μ/100mm	6 μ/100mm

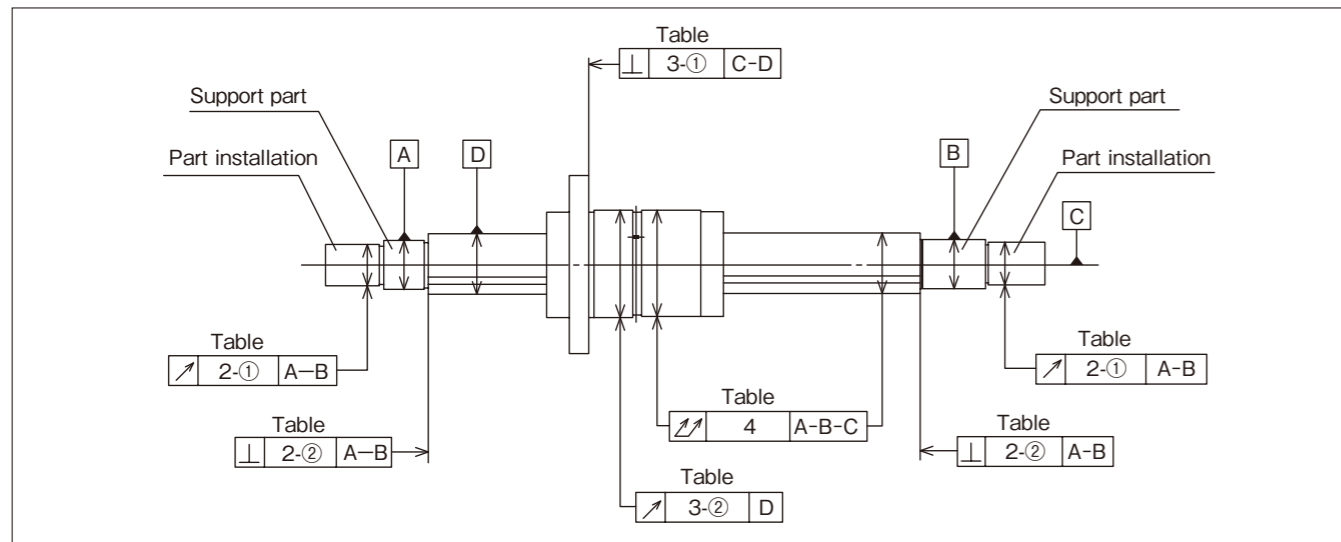

Table 2 Tolerance relative to axial line of support part of spline shaft

(Unit : μm)

Shaft dia. (mm)	Relative to axial line of support part of spline shaft					
	①Radial runout of periphery of part installation area			②Perpendicularity of end face of spline part		
	Runout (Max)			Perpendicularity (Max)		
	Normal (No mark)	High (H)	Precision (P)	Normal (No mark)	High (H)	Precision (P)
6	33	14	8	22	9	6
8	33	14	8	22	9	6
10	41	17	10	22	9	6
12	41	17	10	22	9	6
13	46	19	12	27	11	8
16	46	19	12	27	11	8
20	46	19	12	27	11	8
25	53	22	13	33	13	9
30	53	22	13	33	13	9
40	62	25	15	39	16	11
50	62	25	15	39	16	11
60	73	29	17	46	19	13
80	73	29	17	46	19	13
100	86	34	20	54	22	15

Table 3 Tolerance relative to axial line of spline shaft

(Unit : μm)

Shaft dia. (mm)	Relative to axial line of spline shaft					
	①Perpendicularity of mounting surface of spline nut flange			②Radial runout of periphery of spline nut		
	Perpendicularity (Max)			Runout (Max)		
	Normal (No mark)	High (H)	Precision (P)	Normal (No mark)	High (H)	Precision (P)
6	27	11	8	27	11	5
8	27	11	8	27	11	5
10	33	13	9	33	13	6
12	33	13	9	33	13	6
13	39	16	11	39	16	7
16	39	16	11	39	16	7
20	39	16	11	39	16	7
25	46	19	13	46	19	8
30	46	19	13	46	19	8
40	54	22	15	54	22	10
50	54	22	15	54	22	10
60	63	25	18	63	25	12
80	63	25	18	63	25	12
100	72	29	20	72	29	14

Table 4 Full radial runout of axial line of spline shaft

(Unit : μm)

Overall spline shaft length (mm)	SBS 6, 10, 13, 16, 20, 25, 30, 40, 50, 60, 80, 100																				
	SBS 6 SBS 8			SBS 10 SBS 12			SBS 13 SBS 16 SBS 20			SBS 25 SBS 30			SBS 40 SBS 50			SBS 60 SBS 80			SBS 100		
Above ~ Or less	Normal	High (H)	Precision (P)	Normal	High (H)	Precision (P)	Normal	High (H)	Precision (P)	Normal	High (H)	Precision (P)	Normal	High (H)	Precision (P)	Normal	High (H)	Precision (P)	Normal	High (H)	Precision (P)
~200	72	46	26	59	36	20	56	34	18	53	32	18	53	32	16	51	30	16	51	30	16
200~315	133	89	57	83	54	32	71	45	25	58	39	21	58	36	19	55	34	17	53	32	17
315~400				103	68	41	83	53	31	70	44	25	63	39	21	58	36	19	55	34	17
400~500				123	82	51	95	62	38	78	50	29	68	43	24	61	38	21	57	35	19
500~630							112	75	46	88	57	34	74	47	27	65	41	23	60	37	20
630~800							137	92	58	103	68	42	84	54	32	71	45	26	64	40	22
800~1000							170	115	75	124	83	52	97	63	38	79	51	30	69	43	24
1000~1250										151	102	65	114	76	47	90	59	35	76	48	28
1250~1600										190	130	85	139	93	59	106	70	43	86	55	33
1600~2000													173	118	77	128	86	54	99	65	40
2000~2500																156	106	68	117	78	49
2500~3150																196	134	88	143	96	61

Maximum length of spline shafts

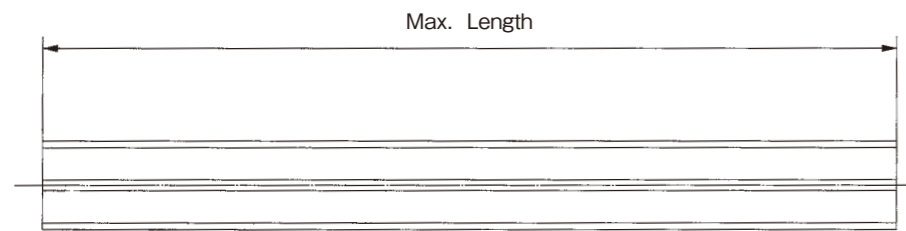

Model Number	Max length (mm)
SBS 6	1200
SBS 8	1200
SBS 10	1400
SBS 13	1400
SBS 16	2500
SBS 20	2500
SBS 25	2500
SBS 30	2500

- Maximum length of spline shafts is shown in the table. Longer shafts are also available for your specific application. Please contact TSK for details.

Incomplete length of spline shaft groove

- The table below shows incomplete length of spline groove (Lt) when stepped machining (Df) is required as shown below.
(In case incomplete groove length other than those shown in the table is required, contact TSK for details.)

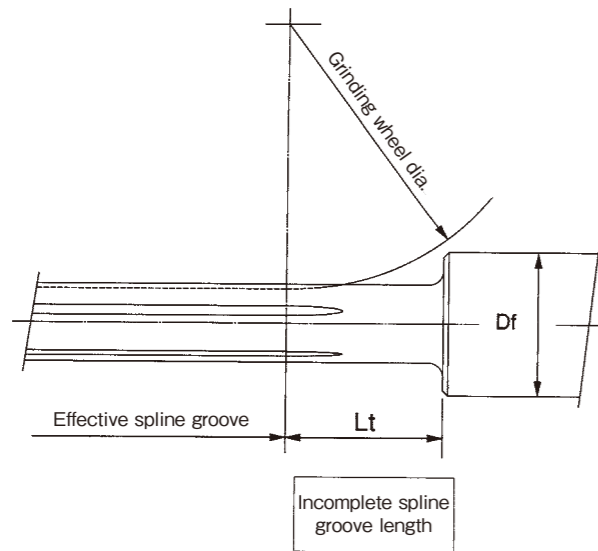

Incomplete groove length (Lt)

Model #	Df (mm)												
	6	8	10	13	16	20	25	30	35	40	50	60	70
6	8	14	18	21	24	27	-	-	-	-	-	-	-
8	-	8	14	19	22	24	26	29	-	-	-	-	-
10	-	-	-	14	20	25	29	33	-	-	-	-	-
13	-	-	-	-	16	22	27	31	34	-	-	-	-
16	-	-	-	-	-	18	24	29	32	35	-	-	-
20	-	-	-	-	-	-	19	25	29	33	38	-	-
25	-	-	-	-	-	-	-	19	25	29	36	40	-
30	-	-	-	-	-	-	-	-	19	25	33	38	42

Clearance (Preload)

For TSK ball splines, appropriate clearance (preload) is necessary in order to obtain long life and high accuracy. Please select correct clearance (preload) for the application.

(Unit : mm)

Shaft dia.	Preload symbol			
	E0 (Medium preload)	E (Light preload)	Normal (No symbol)	E1 (Clearance)
6		-0.006	-0.001	+0.004
8	-	~	~	~
10		-0.001	+0.004	+0.010
13	-0.012	-0.008	-0.002	+0.005
16	~	~	~	~
20	-0.006	-0.002	+0.005	+0.012
25	-0.014	-0.008	-0.002	+0.006
30	~	~	~	~
30	-0.006	-0.002	+0.006	+0.015
Application	<ul style="list-style-type: none"> • Receiving severe vibration or shock. • Receiving overhanged load. • Places requiring high stiffness and exposed. 	<ul style="list-style-type: none"> • Receiving weak vibration or shock. • Places with alternating loads. • Where small torsional load is expected. 	<ul style="list-style-type: none"> • When smooth driving with small power is necessary. • Quite small vibration is applied. • Receiving load (torque) in one direction only. 	<ul style="list-style-type: none"> • For very long shaft. • Where temperature change is expected. • When 2 axes are used on same plane.

Fitting

Unit : mm

Model #	Housing bore tolerance	
	Clearance fit (H7)	Tight fit (J7)
6	+0.018	+0.010
8	0	-0.008
10	+0.021	+0.012
13	0	-0.009
16	+0.025	+0.014
20		-0.011
25	0	-0.011
30		

When installing a spline nut into the housing, we recommend clearance fit (H7) for general use. If strict accuracy and rigidity are required, tight fit (J7) is recommended.

Dimensions of key way and key

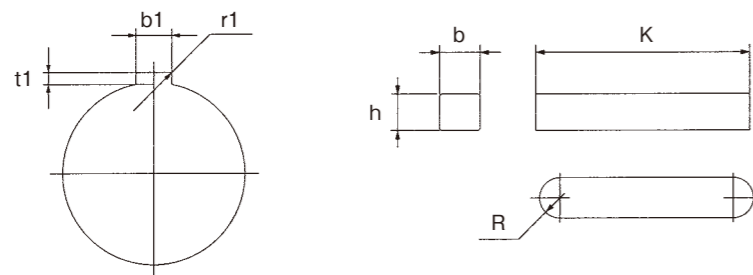

Unit : mm

Model #	Key way					Key						
	b_1	Tol.	t_1	Tol.	r_1	b	Tol.	h	Tol.	K	Tol.	R
6	2.5	± 0.013	1.5	$+0.1$	0.1	2.5	$+0.016$	2.5	0	Refer to dimensional table of each model	0 -0.2	1.25
8			3			1.7	3	$+0.006$	3			-0.025
10	3.5	± 0.015	1.8	0	3.5	$+0.024$	3.5	0	1.75			
13									4			4
16												
20												
25												
30												

Critical speed

For high speed revolution application of spline shaft, shaft length and diameter need to be selected considering strength, rigidity and critical speed. The figure below shows critical speed of ball spline shafts. In selecting shaft diameter of the ball spline, operating rotational speed should be at least 20% higher or lower than the critical speed.

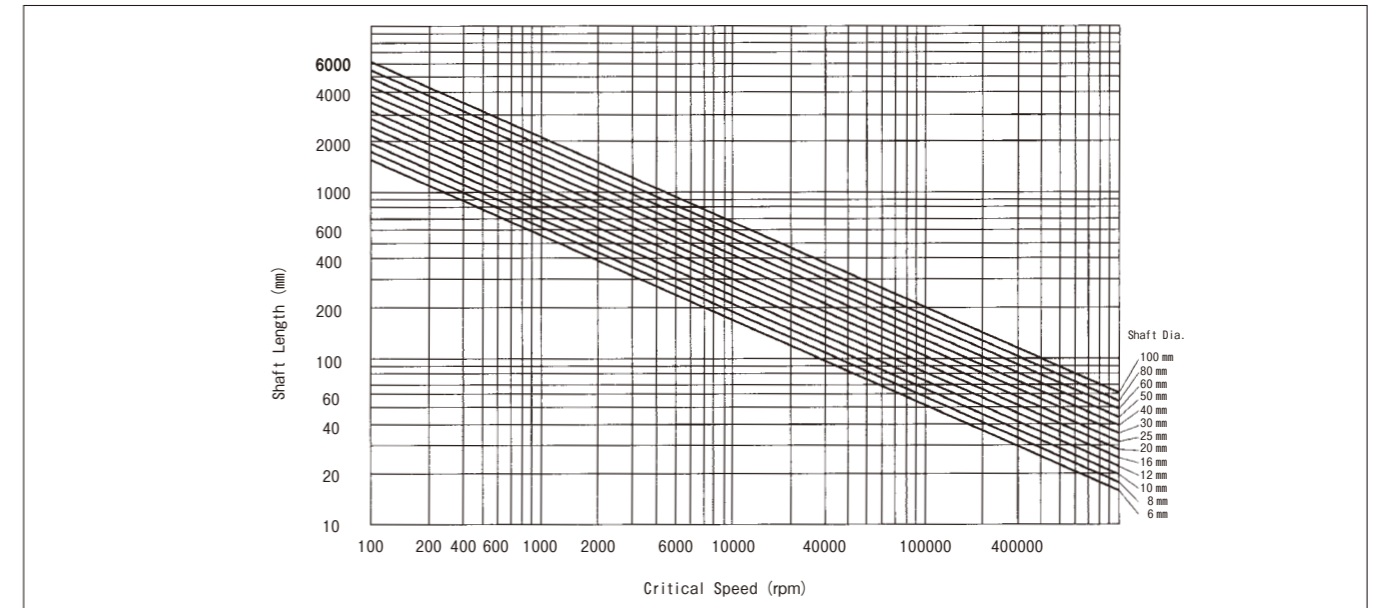

How to apply preload

Preload can be applied to TSK ball splines.

It is effective in enhancing rigidity, elimination of backlash or extension of service life.

In order to apply preload, two sleeves with flange are installed to housing in the manner shown in figures below. The amount of preload can be controlled by tightening adjustment screw.

In general, optimum amount of preload is about one third of transmitting torque.

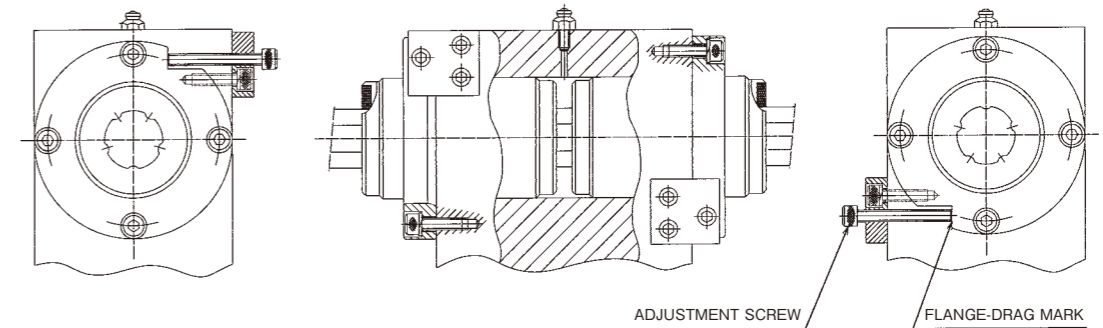

Example of installation of the sleeve

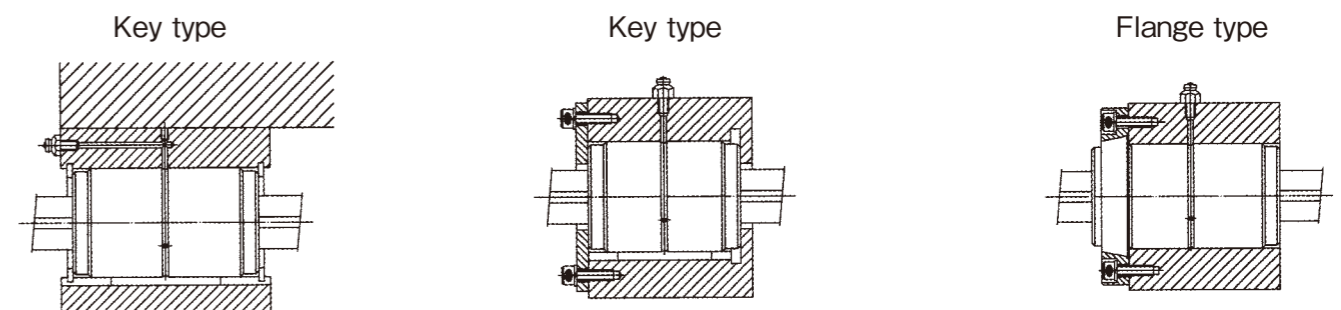

■ Precautions for use

TSK ball spline is precision mechanical component. Improper handling may damage it, and it could also cause functional failure. Please read following instructions carefully before using TSK ball spline.

● Installing the spline nut

- When installing the spline nut into the housing, do not hit the spline nut directly.

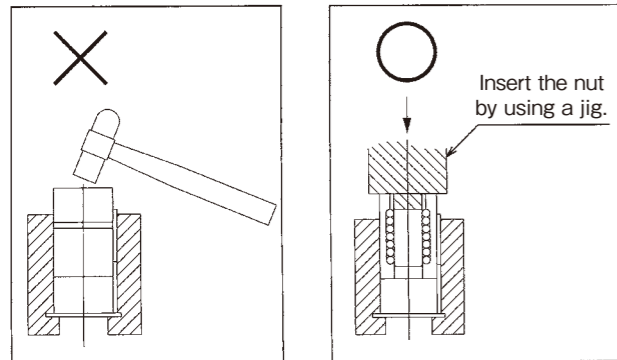

- When fixing the spline nut to the housing, do not press the outer surface of spline nut by set screw as shown in the figure below. It may deform the spline nut which could be a cause of malfunction.

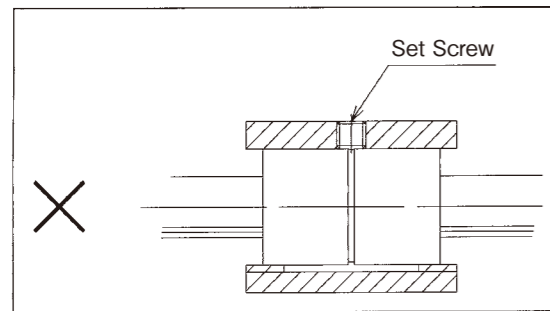

- The moment load caused by improper parallelism and perpendicularity relative to mounting surfaces of spline nut, also too much runout deviation relative to mounting part of spline shaft may increase operation noise and vibration. This moment load also leads to serious affect in reducing life expectancy of the spline unit. Please be careful thoroughly when installing it.

● Confirmation of identification mark

- Spline nut and spline shaft have identification marks as shown in the figure below. When installing the spline shaft into the spline nut, please confirm identification marks, direction of characters and relative position before re-assembling.

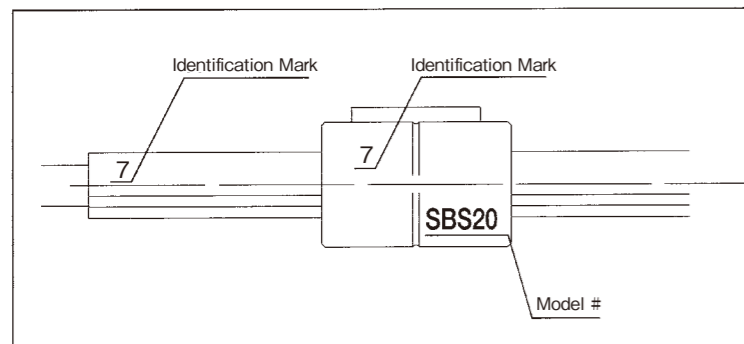

● Protection of ball retainer

- During assembly, if the spline nut runs on cut end part of the spline shaft, it may cause damage to the ball retainer. Use of the nut stopper (e.g. tape, snap ring) is recommended so that the spline nut does not overrun.

● Prevention from entering dust and process after machining of spline shaft

- When assembly, please be careful of entrance of dust. Entrance of dust, especially due to careless rinse after machining of the spline shaft, it may cause not only reduction of running accuracy but also service life. After machining, please chamfer all edges of the spline shaft and remove burrs remained on spline grooves using round file. It also makes the insertion of the spline nut easier.

● Prohibition on additional machining of the spline nut

- Please do not do additional machining on the spline nut. It may reduce running accuracy and rigidity of the product, also, it may damage to the ball circulating function. Please contact TSK when additional machining is necessary.

● Lubrication and rust prevention

- Unless special instruction provided, turbine oil (# 90 ~ #180) is applied to TSK ball spline before shipping. If grease lubrication is required, we apply lithium soap base grease No. 2 (Shell Alvania No. 2 or equivalent). Since these lubricants are applied as for rust prevention purpose, too, replenish same type grease after installing the spline unit to the equipment. When replenishing the lubricant, apply new lubricant after removing used lubricant adhered to the product thoroughly.

● Restriction on operating temperature

- The environmental temperature of TSK Ball Splines is limited below 80 degrees centigrade since synthetic resin is used for the ball retainer of TSK Ball Splines.