

ECA30

How to Order

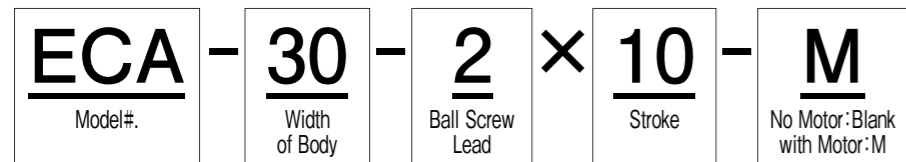

Compact type

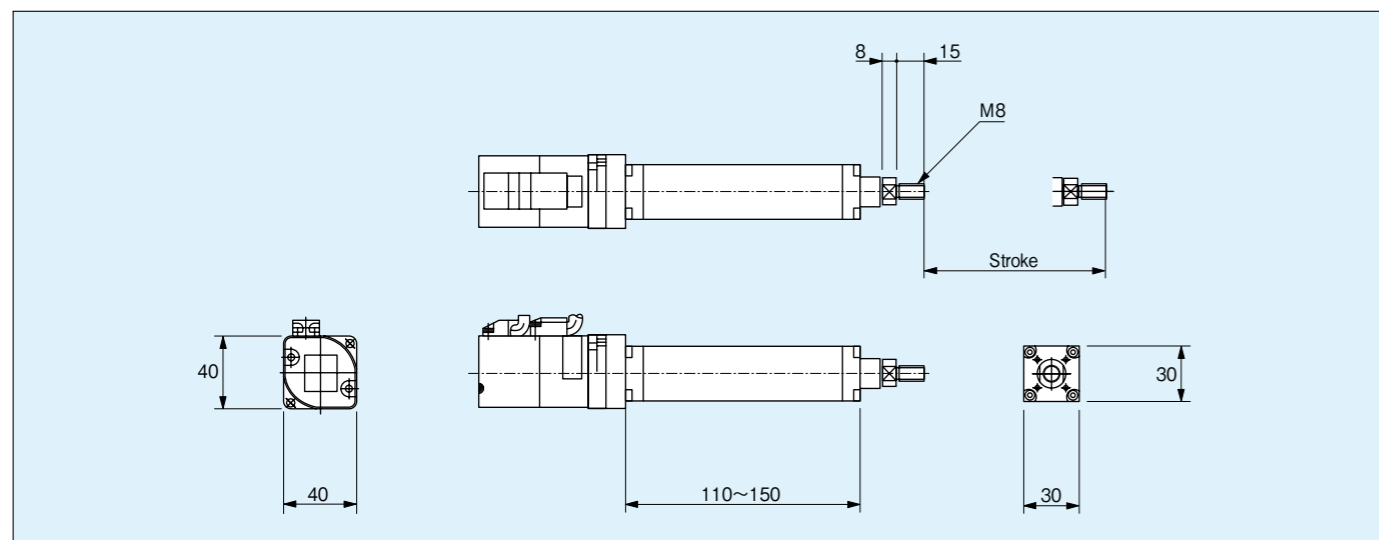

Specification

ECA 30	Unit	Motor (30W)
Continuous velocity	mm/s	100
Stroke	mm	10
		20
		30
		50
Continuous force	N	161
Max. force	N	644
Ball screw shaft dia.	mm	6
Ball screw lead	mm	2
Repeatability	mm	±0.02
Motor rated torque	N.m	0.095
Rod Dia.	mm	16
Tip dia. of Rod screw	M	8

The direction of motor other than above can be provided upon the request.
The mounting flange of motor for your designated motor can be provided.

ECA40

How to Order

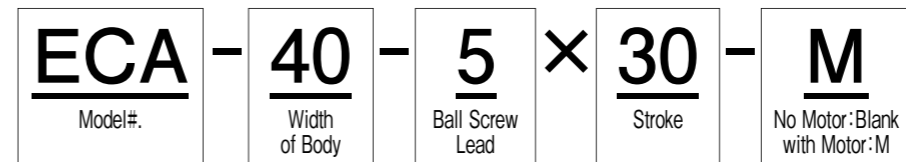

Compact type

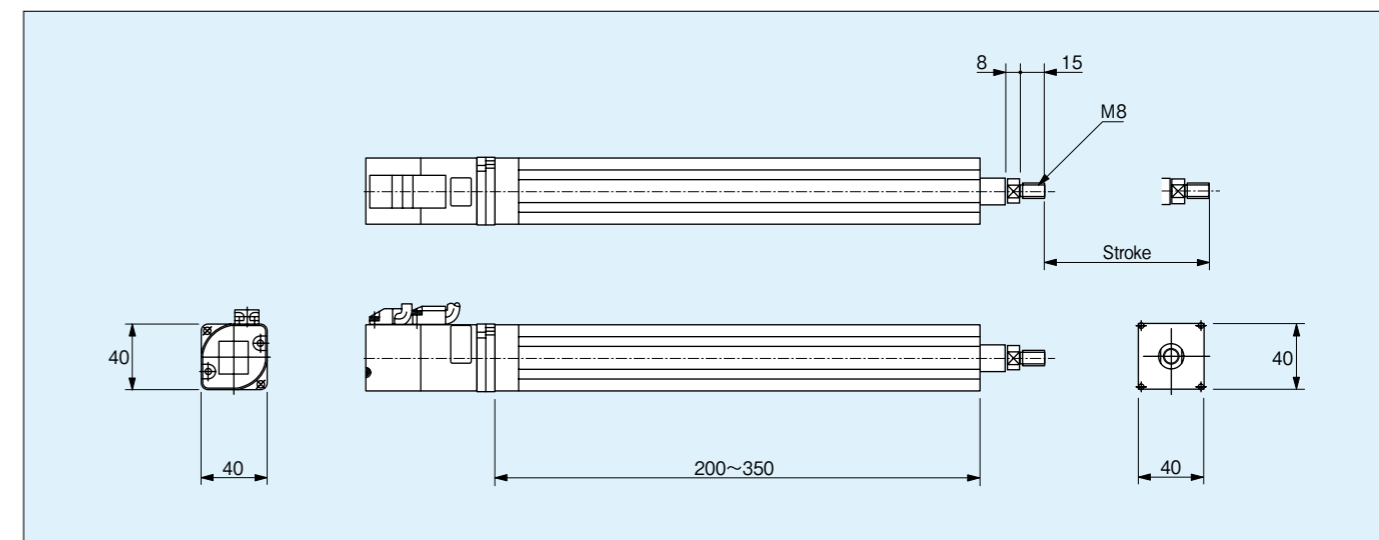

Specification

ECA 40	Unit	Motor (50W)
Continuous velocity	mm/s	250
Stroke	mm	50
		100
		150
		200
Continuous force	N	239
Max. force	N	955
Ball screw shaft dia.	mm	8
Ball screw lead	mm	5
Repeatability	mm	±0.02
Motor rated torque	N.m	0.16
Rod Dia.	mm	16
Tip dia. of Rod screw	M	8

The direction of motor other than above can be provided upon the request.
The mounting flange of motor for your designated motor can be provided.

ECA60

Standard type

How to Order

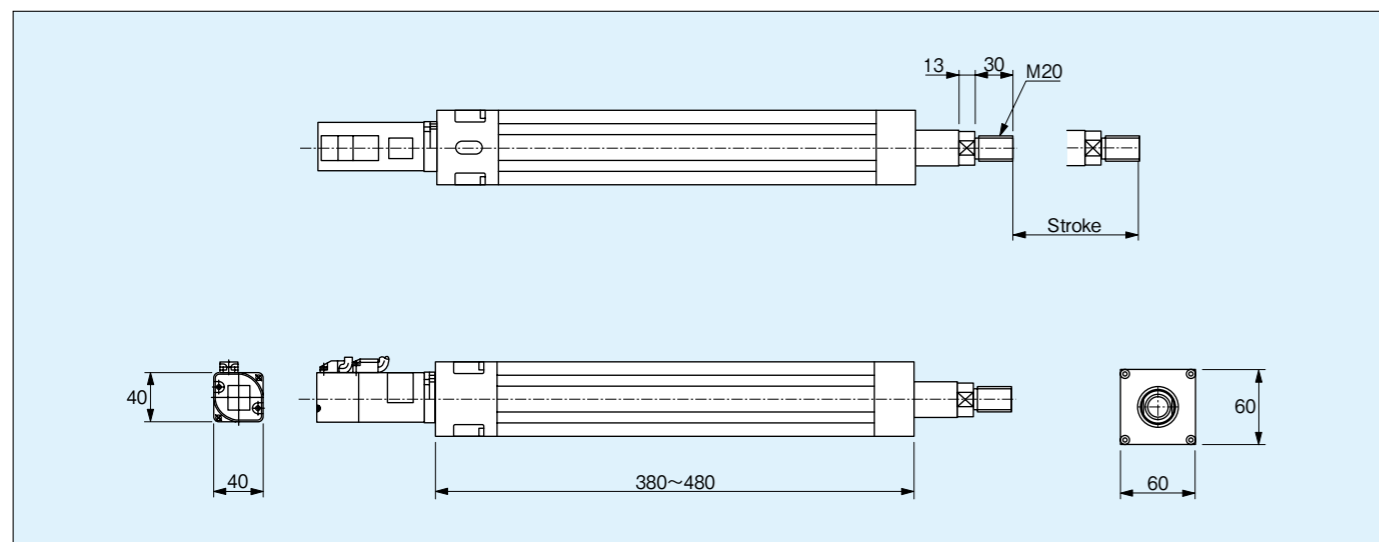
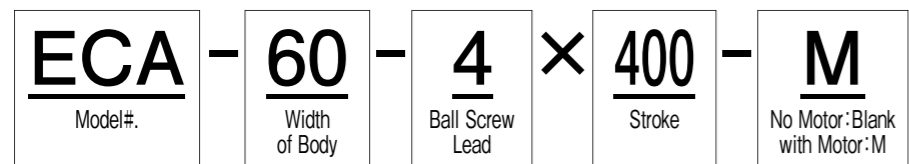

Specification

ECA 60	Unit	Motor (100W)
Continuous velocity	mm/s	200
Stroke	mm	200
		300
Continuous force	N	402
Max. force	N	1608
Ball screw shaft dia.	mm	14
Ball screw lead	mm	4
Repeatability	mm	±0.02
Motor rated torque	N.m	0.32
Rod Dia.	mm	28
Tip dia. of Rod screw	M	20

The direction of motor other than above can be provided upon the request.
 The mounting flange of motor for your designated motor can be provided.

ECA80

Standard type

How to Order

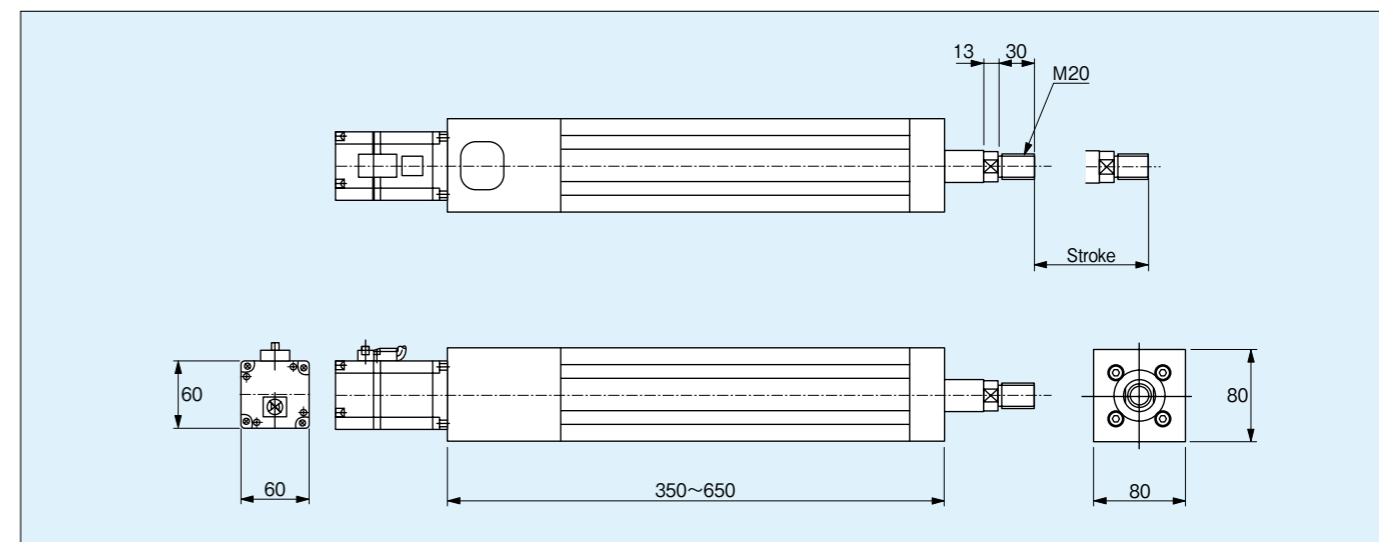
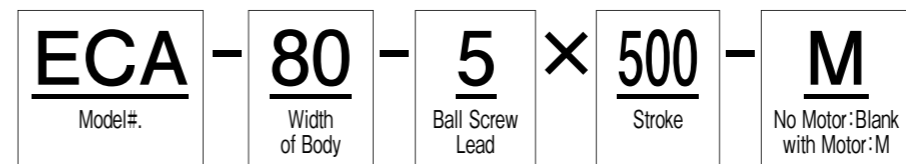

Specification

ECA 80	Unit	Motor (200W)
Continuous velocity	mm/s	250
Stroke	mm	200
		300
		400
		500
Continuous force	N	643
Max. force	N	1930
Ball screw shaft dia.	mm	14
Ball screw lead	mm	5
Repeatability	mm	±0.02
Motor rated torque	N.m	0.64
Rod Dia.	mm	27

The direction of motor other than above can be provided upon the request.
 The mounting flange of motor for your designated motor can be provided.