

TSK Miniature Guide LMBM series

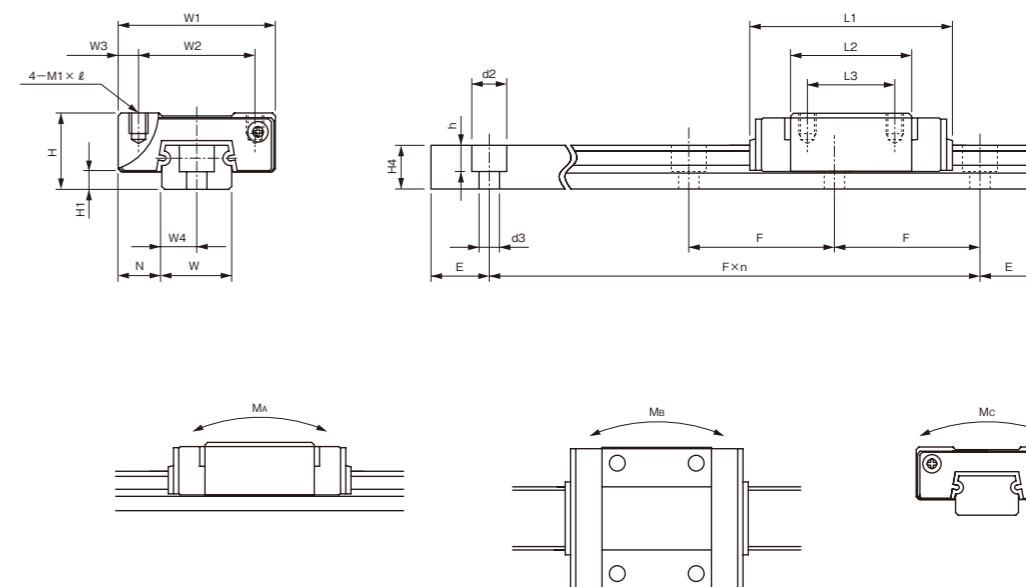

Model Number	Dimensions of Assembly				Carriage Dimensions					
	H	H1	N	W1	W2	W3	L1	L2	L3	M1 × ℓ
LMBM 5	6	1.5	3.5	12	8	2	20	11	-	M2 × 1.5
LMBM 5S							26			
LMBM 7C	8	1.5	5	17	12	2.5	19	9	-	M2 × 2.5
LMBM 7CS							27			
LMBM 7							23.5			
LMBM 7S							31.5			
LMBM 7L							33			
LMBM 7LS							41			
LMBM 9C	10	2.2	5.5	20	15	2.5	21.5	10.5	-	M3 × 3
LMBM 9CS							29.5			
LMBM 9							31			
LMBM 9S							39			
LMBM 9L							41			
LMBM 9LS							49			
LMBM 12C	13	3	7.5	27	20	3.5	25	10.8	-	M3 × 3.5
LMBM 12CS							33			
LMBM 12							35			
LMBM 12S							43			
LMBM 12L							48			
LMBM 12LS							56			
LMBM 15C	16	4	8.5	32	25	3.5	32	14.7	-	M3 × 4
LMBM 15CS							42			
LMBM 15							43			
LMBM 15S							53			
LMBM 15L							61			
LMBM 15LS							71			

Rail Dimensions								Basic Load Rating [N]			Static Rated Moment [N · M]			Weight	
W	W4	H4	d2	d3	h	E	F	C	Co	Ma	Mb	Mc	Carriage [kg]	Rail [kg/m]	
5	2.5	4	3.5	2.4	1	5	15	430	770	1.3	1.3	2.1	0.005 0.005	0.14	
7	3.5	4.7	4.2	2.4	2.3	5	15	750	1010	1.8	1.8	3.7	0.011 0.012	0.22	
								1000	1510	3.0	3.0	5.6	0.013 0.014		
								1430	2510	8.3	8.3	9.2	0.019 0.020		
9	4.5	5.5	6	3.5	3.3	7.5	20	1220	1590	3.5	3.5	7.4	0.010 0.011	0.32	
								1750	2650	8.8	8.8	12.4	0.018 0.019		
								2330	3970	16.5	16.5	18.5	0.027 0.028		
12	6	7.5	6	3.5	4.5	10	25	1730	2070	3.4	3.4	12.0	0.022 0.023	0.59	
								2610	3720	11.3	11.3	21.4	0.037 0.038		
								3560	5790	32.2	32.2	33.3	0.056 0.057		
15	7.5	9.5	6	3.5	4.5	15	40	2880	3340	6.8	6.8	23.8	0.047 0.050	0.98	
								4340	6000	23.2	23.2	42.6	0.070 0.073		
								5930	9340	65.8	65.8	66.4	0.109 0.112		

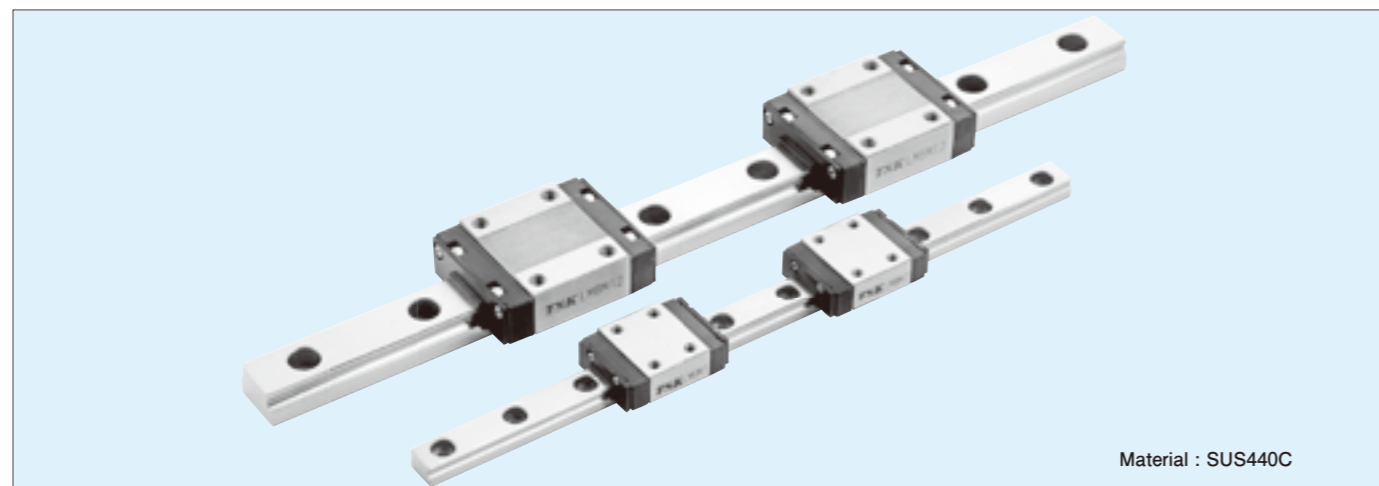