

TSK シャフトサポート Shaft Supports

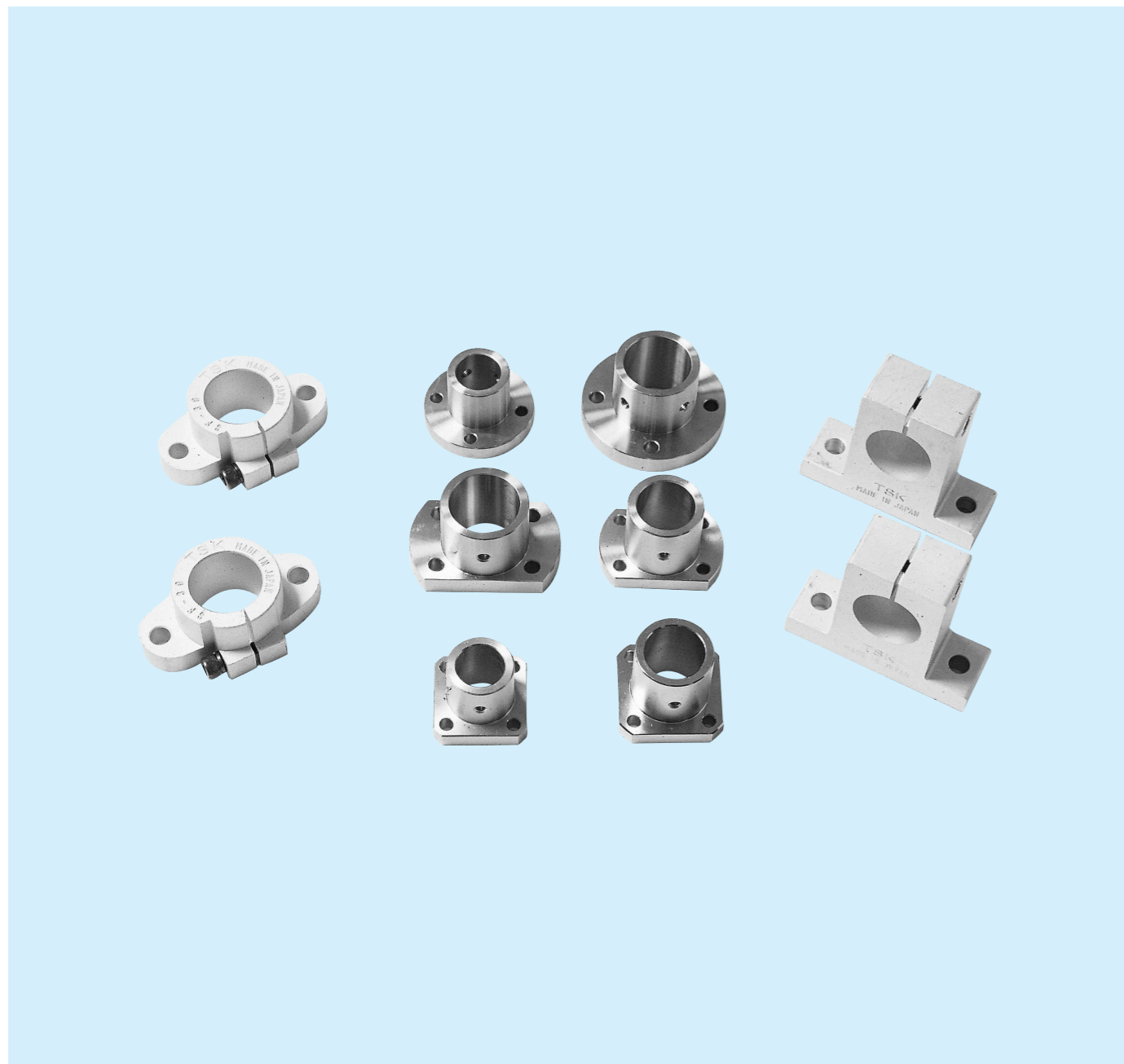

■丸フランジ型 STHRTシリーズ

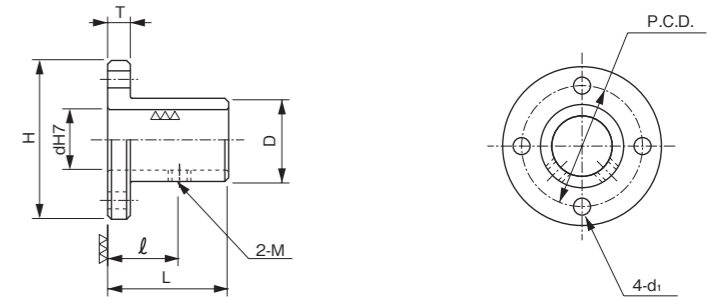
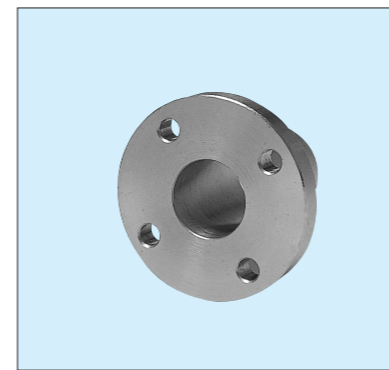

軸径 (mm)	型式	主要寸法								
		d	L	H	D	T	ℓ	P.C.D.	M	d ₁
8	STHRT-8	8	16	28	12	5	10	20	M3×0.5	3.5
10	STHRT-10	10	20	30	14	5	12	22	M3×0.5	3.5
12	STHRT-12	12	24	36	16	6	15	26	M4×0.7	4.5
13	STHRT-13	13	24	38	18	6	15	28	M4×0.7	4.5
16	STHRT-16	16	32	42	22	6	19	32	M4×0.7	4.5
20	STHRT-20	20	32	50	28	8	20	39	M5×0.8	5.5
25	STHRT-25	25	38	55	33	8	23	44	M5×0.8	5.5
30	STHRT-30	30	38	66	38	10	24	52	M6×1	6.6

●呼び型番



■角フランジ型 STHSTシリーズ

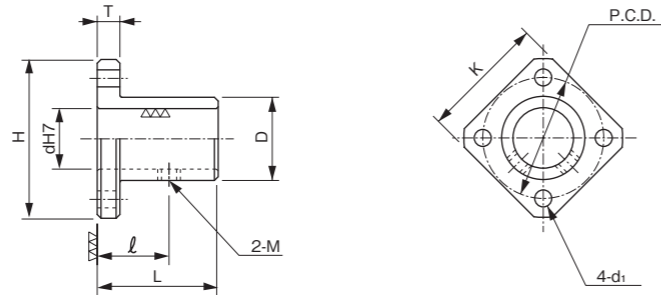
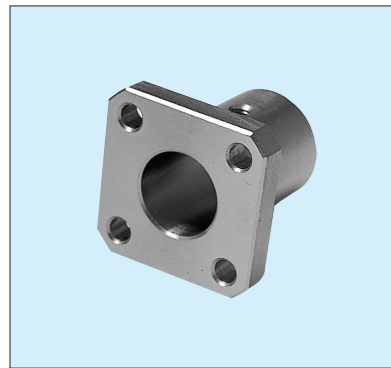

軸径 (mm)	型 式	主 要 寸 法									
		d	L	H	D	T	ℓ	P.C.D.	K	M	d ₁
8	STHST-8	8	16	28	12	5	10	20	22	M3×0.5	3.5
10	STHST-10	10	20	30	14	5	12	22	23	M3×0.5	3.5
12	STHST-12	12	24	36	16	6	15	26	28	M4×0.7	4.5
13	STHST-13	13	24	38	18	6	15	28	30	M4×0.7	4.5
16	STHST-16	16	32	42	22	6	19	32	33	M4×0.7	4.5
20	STHST-20	20	32	50	28	8	20	39	39	M5×0.8	5.5
25	STHST-25	25	38	55	33	8	23	44	44	M5×0.8	5.5
30	STHST-30	30	38	66	38	10	24	52	52	M6×1	6.6

●呼び型番



■コンパクトフランジ型 STHCTシリーズ

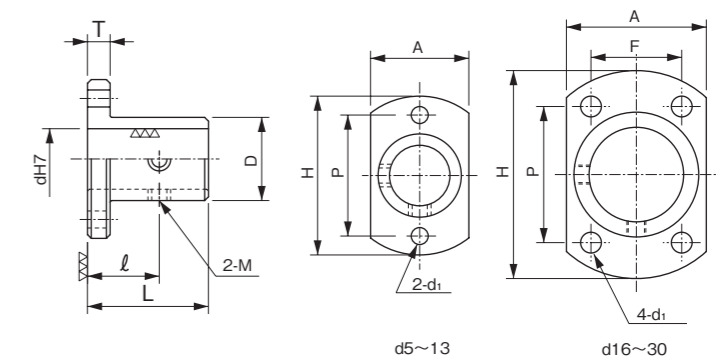
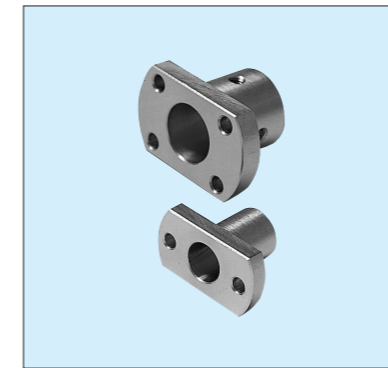

軸径 (mm)	型 式	主 要 寸 法										
		d	L	H	A	F	D	T	ℓ	P	M	d ₁
5	STHCT-5	5	12	25	10	—	10	3.5	7	18	M3×0.5	3.5
6	STHCT-6	6	15	28	12	—	12	3.5	7	20	M3×0.5	3.5
8	STHCT-8	8	16	28	16	—	12	5	10	20	M3×0.5	3.5
10	STHCT-10	10	20	30	18	—	14	5	12	22	M3×0.5	3.5
12	STHCT-12	12	24	36	20	—	16	6	15	26	M4×0.7	4.5
13	STHCT-13	13	24	38	22	—	18	6	15	28	M4×0.7	4.5
16	STHCT-16	16	32	42	26	16	22	6	19	28	M4×0.7	4.5
20	STHCT-20	20	32	50	32	22	28	8	20	31	M5×0.8	5.5
25	STHCT-25	25	38	55	37	24	33	8	23	36	M5×0.8	5.5
30	STHCT-30	30	38	66	42	27	38	10	24	41	M6×1	6.6

●呼び型番



■シャフトサポート SFシリーズ

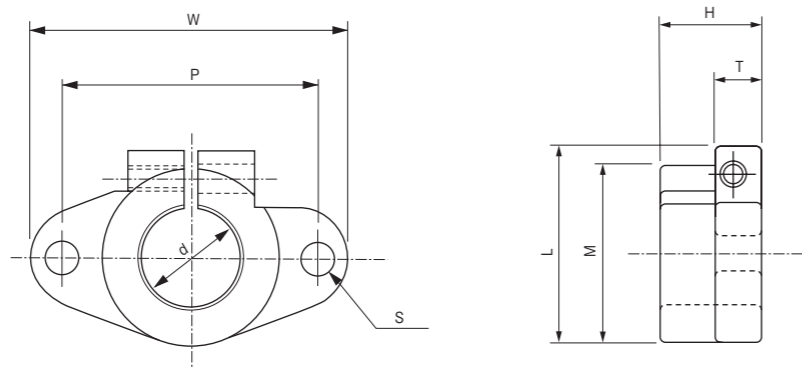
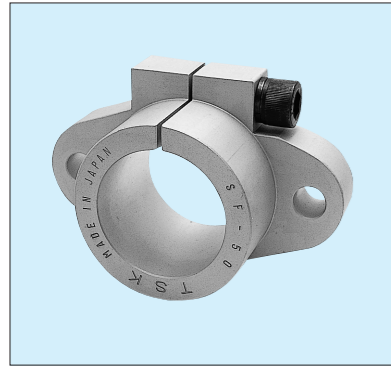

軸径 (mm)	型 式	主 要 寸 法									
		d	W	M	L	H	T	P	S	取付ボルト	締付ボルト
10	SF10	10	43	20	24	10	7.5	32	5.5	M 5	M 4
12	SF12	12	47	25	28	13	7.5	36	5.5	M 5	M 4
13	SF13	13	47	25	28	13	7.5	36	5.5	M 5	M 4
16	SF16	16	50	28	31	16	7.5	40	5.5	M 5	M 4
20	SF20	20	60	34	37	20	9	48	7	M 6	M 5
25	SF25	25	70	40	42	25	10	56	7	M 6	M 5
30	SF30	30	80	46	50	30	12	64	9	M 8	M 6
35	SF35	35	92	50	58	35	14	72	12	M10	M 8
40	SF40	40	102	56	67	40	16	80	12	M10	M10
50	SF50	50	122	70	80	50	19	96	14	M12	M12

●呼び型番

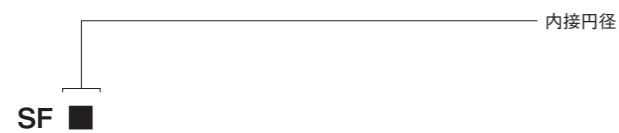

■シャフトサポート SB-Aシリーズ

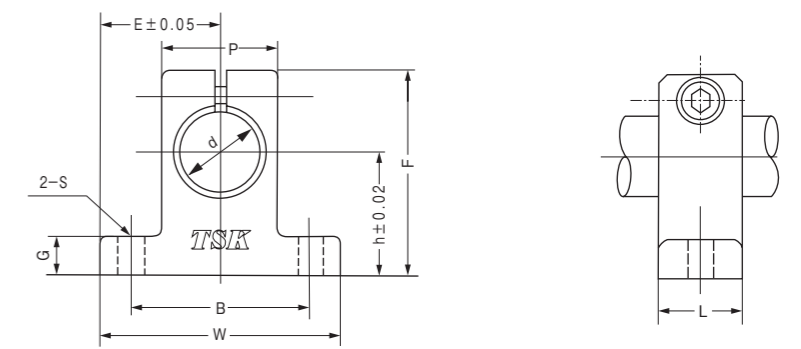
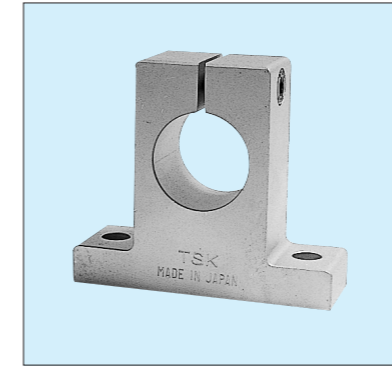

軸径 (mm)	型 式	主 要 寸 法										締め付け ボルトの 呼び	取り付け ボルトの 呼び
		d	h	E	W	L	F	G	P	B	S		
10	SB10A	10	20	21	42	14	33	6	18	32	5.5	M 4	M 5
12	SB12A	12	23	21	42	14	38	6	20	32	5.5	M 4	M 5
13	SB13A	13	23	21	42	14	38	6	20	32	5.5	M 4	M 5
16	SB16A	16	27	24	48	16	44	8	25	38	5.5	M 4	M 5
20	SB20A	20	31	30	60	20	51	10	30	45	6.6	M 5	M 6
25	SB25A	25	35	35	70	24	60	12	38	56	6.6	M 6	M 6
30	SB30A	30	42	42	84	28	70	12	44	64	9	M 6	M 8
35	SB35A	35	50	49	98	32	85	15	50	74	11	M 8	M10
40	SB40A	40	60	57	114	36	96	15	60	90	11	M 8	M10
50	SB50A	50	70	63	126	40	120	18	74	100	14	M12	M12

●呼び型番

